

AC FILTERING

FLB* RoHS Compliant



PACKAGING MATERIAL

- Aluminium can with soft PU

STANDARDS

IEC 61071-1, IEC 61071-2: Power electronic capacitors
 IEC 60831: Shunt power capacitors of selfhealing type for ac systems having a rated voltage up to and including 1kv
 EN CYWT2.E514025 Certificate: E514025 (approved by UL)

LIFETIME EXPECTANCY

One unique feature of this technology (as opposed to aluminum electrolytic) is how the capacitor reacts at the end of its lifetime.

Unlike aluminum electrolytic film capacitors do not have a catastrophic failure mode. Film capacitors simply experience a parametric loss of capacitance of about 5% from initial value, with no risk of short circuit.

The capacitor continues to be functional even after this 5% decrease.

The FLB series uses metallized polypropylene dielectric, aluminum can, impregnated with soft PU specially treated to have a very high dielectric strength in operating conditions up to 85°C.

The FLB has been designed with overpressure disconnected device. They are suitable for power factor correction and output AC filtering for power converters, UPS systems, solar inverters and motor drives etc.

APPLICATIONS

- The FLB capacitor is particularly designed for AC filtering and power factor correction.

HOT SPOT CALCULATION

See *Hot Spot Temperature*, page 75.

$$\theta_{\text{hot spot}} = \theta_{\text{ambient}} + (P_d + P_t) \times R_{\text{th}}$$

with P_d (Dielectric losses) = $Q \times \text{tg}\delta_0$
 $Q \times \text{tg}\delta_0 \Rightarrow [\frac{1}{2} \times C_n \times (V_{\text{peak to peak}})^2 \times f] \times \text{tg}\delta_0$
 $\text{tg}\delta_0$ (tan delta)
 For polypropylene, $\text{tg}\delta_0 = 2 \times 10^{-4}$ for frequencies up to 1MHz and is independent of temperatures.
 P_t (Thermal losses) = $R_s \times (I_{\text{rms}})^2$

where C_n in Farad I_{rms} in Ampere f in Hertz
 V in Volt R_s in Ohm θ in °C
 R_{th} in °C/W

WORKING TEMPERATURE

According to the power to be dissipated
 -40°C to +85°C

HOW TO ORDER

FLB

Series

A

Case
 A
 B
 C
 D
 E
 F
 G
 H
 J

6

Dielectric
 6 = Polypropylene

V

Voltage
 A = 230V
 I = 400V
 L = 440V
 J = 525V
 N = 660V
 O = 690V

0335

Capacitance
 EIA Code
 0103 = 0.01µF

K

Tolerances
 J = ±5%
 K = ±10%

03

Terminal
 Code
 03 = 3 phase

AC FILTERING

FLB* RoHS Compliant

LIFETIME EXPECTANCY VS HOT SPOT TEMPERATURE AND VOLTAGE

Expected Lifetime Curves (FLB Series)

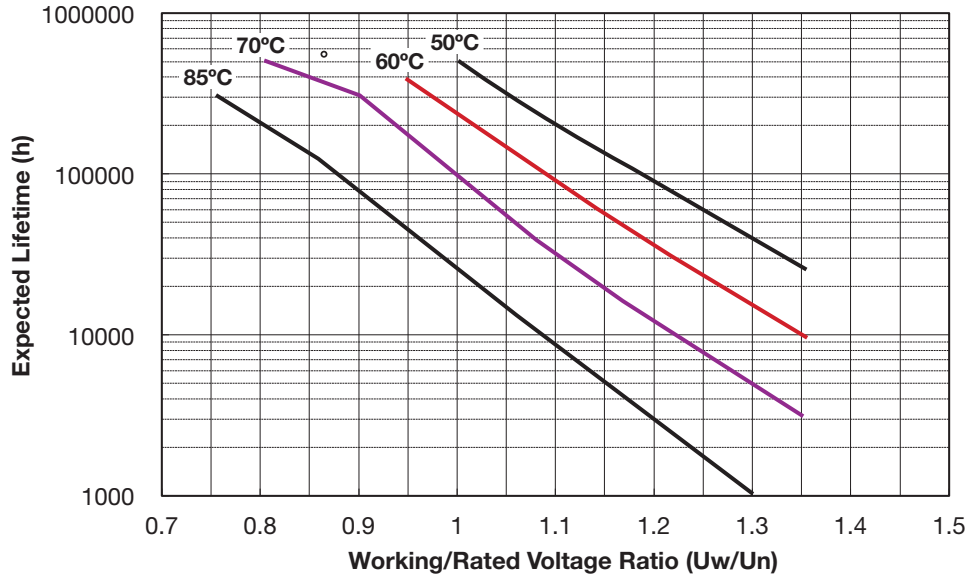

GENERAL DESCRIPTION

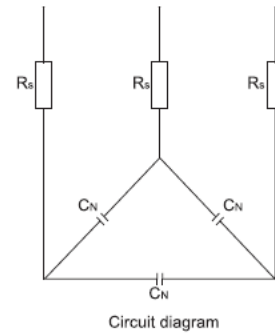
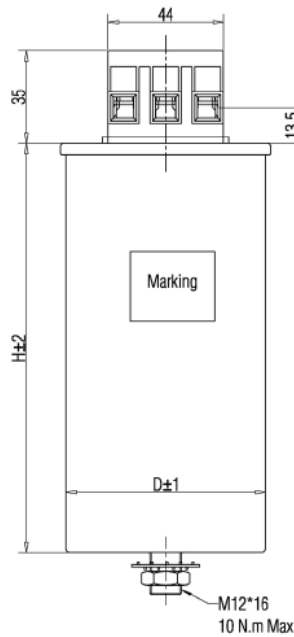
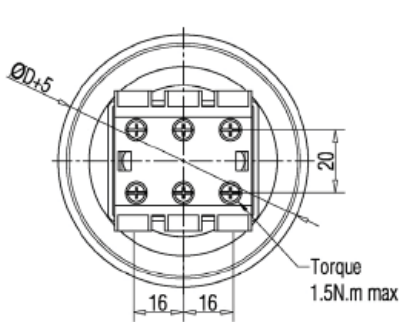

* Rs is external discharge resistor selected from following range by customer. KYOCERA AVX does not provide external discharge capacitor.

DIMENSIONS

Case Ref	OD (mm)	H (mm)
A	85	200
B	85	265
C	85	350
D	116	160
E	116	200
F	116	230
G	116	265
H	136	200
J	136	230

Vrms	Resistor Range
230V	220kΩ~400kΩ
400V	270kΩ~800kΩ
440V	270kΩ~800kΩ
525V	270kΩ~1200kΩ
660V	800kΩ~2000kΩ
690V	800kΩ~1500kΩ

AC FILTERING

FLB* RoHS Compliant



ELECTRICAL CHARACTERISTICS

Climatic category	-40/D (IEC 60068)
Test voltage between terminals @ 25°C	2.15 x V _{rms}
Capacitance range C _n	3*20.3µF to 3*335µF
Capacitance Tolerances:	±5%, ±10%
Rated AC Voltage:	V _{rms} 230V to 690V
Dielectric:	Polypropylene
Lifetime (ΔC/C ≤ 5%):	100,000hrs @ U _i & 70°C

RATINGS AND PART NUMBER REFERENCE – POLYPROPYLENE DIELECTRIC

Cap (µF)	Rated Voltage (V)	Part No.	Case Code	Diameter ±2 (mm)	H ±2 (mm)	Output (kvar)	I _{rms} (A)	V/µs (Volt/sec)	I _{Peak} (A)	Packaging Method	
										Box Qty (mm)	Dimension
V_{rms} = 230V Voltage Code: A											
3 x 200.6	230	FLBB6A0207K03	B	85.0	265.0	10.0	25.1	37.0	7530	8	375*285*365
3 x 200.6	230	FLBD6A0207K03	D	116.0	160.0	10.0	25.1	37.0	7530	5	375*285*235
3 x 250.7	230	FLBC6A0257K03	C	85.0	350.0	12.5	31.4	37.0	9420	8	375*285*435
3 x 250.7	230	FLBE6A0257K03	E	116.0	200.0	12.5	31.4	37.0	9420	5	375*285*365
3 x 300.9	230	FLBC6A0307K03	C	85.0	350.0	15.0	37.7	37.0	11310	8	375*285*435
3 x 300.9	230	FLBE6A0307K03	E	116.0	200.0	15.0	37.7	37.0	11310	5	375*285*365
3 x 335.0	230	FLBF6A3356K03	F	116.0	230.0	16.7	41.9	37.0	12570	5	375*285*365
V_{rms} = 400V Voltage Code: I											
3 x 66.3	400	FLBA6I0666K03	A	85.0	200.0	10.0	14.4	65.0	4320	8	375*285*365
3 x 82.9	400	FLBA6I0826K03	A	85.0	200.0	12.5	18.0	65.0	5400	8	375*285*365
3 x 99.5	400	FLBA6I0996K03	A	85.0	200.0	15.0	21.6	65.0	6480	8	375*285*365
3 x 110.7	400	FLBB6I0117K03	B	85.0	265.0	16.7	24.1	65.0	7230	8	375*285*365
3 x 110.7	400	FLBD6I0117K03	D	116.0	160.0	16.7	24.1	65.0	7230	5	375*285*235
3 x 132.6	400	FLBB6I1326K03	B	85.0	265.0	20.0	28.8	65.0	8640	8	375*285*365
3 x 132.6	400	FLBD6I1326K03	D	116.0	160.0	20.0	28.8	65.0	8640	5	375*285*235
3 x 165.8	400	FLBB6I1656K03	B	85.0	265.0	25.0	36.1	65.0	10830	8	375*285*365
3 x 165.8	400	FLBE6I1656K03	E	116.0	200.0	25.0	36.1	65.0	10830	5	375*285*365
3 x 198.9	400	FLBH6I1986K03	H	136.0	200.0	30.0	43.3	65.0	12990	4	375*285*365
V_{rms} = 440V Voltage Code: L											
3 x 68.5	440	FLBA6L0686K03	A	85.0	200.0	12.5	16.4	72.0	4920	8	375*285*365
3 x 77.0	440	FLBA6L0776K03	A	85.0	200.0	14.1	18.5	72.0	5550	8	375*285*365
3 x 77.0	440	FLBD6L0776K03	D	116.0	160.0	14.1	18.5	72.0	5550	5	375*285*235
3 x 82.2	440	FLBA6L0826K03	A	85.0	200.0	15.0	19.7	72.0	5910	8	375*285*365
3 x 92.6	440	FLBA6L0926K03	A	85.0	200.0	16.9	22.2	72.0	6660	8	375*285*365
3 x 103.0	440	FLBB6L1036K03	B	85.0	265.0	18.8	24.7	72.0	7410	8	375*285*365
3 x 103.0	440	FLBD6L1036K03	D	116.0	160.0	18.8	24.7	72.0	7410	5	375*285*235
3 x 109.0	440	FLBB6L1096K03	B	85.0	265.0	20.0	26.2	72.0	7860	8	375*285*365
3 x 109.0	440	FLBD6L1096K03	D	116.0	160.0	20.0	26.2	72.0	7860	5	375*285*235
3 x 123.3	440	FLBB6L1236K03	B	85.0	265.0	22.5	29.5	72.0	8850	8	375*285*365
3 x 123.3	440	FLBD6L1236K03	D	116.0	160.0	22.5	29.5	72.0	8850	5	375*285*235
3 x 137.0	440	FLBB6L1376K03	B	85.0	265.0	25.0	32.8	72.0	9840	8	375*285*365
3 x 137.0	440	FLBE6L1376K03	E	116.0	200.0	25.0	32.8	72.0	9840	5	375*285*365
3 x 154.0	440	FLBB6L1546K03	B	85.0	265.0	28.1	36.9	72.0	11070	8	375*285*365
3 x 154.0	440	FLBE6L1546K03	E	116.0	200.0	28.1	36.9	72.0	11070	5	375*285*365
3 x 164.4	440	FLBC6L1646K03	C	85.0	350.0	30.0	39.4	72.0	11820	8	375*285*435
3 x 164.4	440	FLBE6L1646K03	E	116.0	200.0	30.0	39.4	72.0	11820	5	375*285*365
3 x 180.9	440	FLBH6L1806K03	H	136.0	200.0	33.0	43.3	72.0	12990	2	375*285*365

* Insert K for 10% capacitance tolerance (standard); J (+5%) and M (+20%) tolerances available on request.

Values outside this standard range may be available – please contact KYOCERA AVX for any special requirements.

KYOCERA AVX reserves the right to supply capacitors to a tighter capacitance tolerance or higher voltage rating, in the same case size.

AC FILTERING

FLB* RoHS Compliant



RATINGS AND PART NUMBER REFERENCE – POLYPROPYLENE DIELECTRIC

Cap (µF)	Rated Voltage (V)	Part No.	Case Code	Diameter ±2 (mm)	H ±2 (mm)	Output (kvar)	I rms (A)	V/µs (Volt/sec)	I Peak (A)	Packaging Method	
										Box Qty (mm)	Dimension
V_{rms} = 525V Voltage Code: J											
3 x 38.5	525	FLBA6J0386K03	A	85.0	200.0	10	11.0	86.0	3300	8	375*285*365
3 x 48.1	525	FLBA6J0486K03	A	85.0	200.0	12.5	13.7	86.0	4110	8	375*285*365
3 x 53.1	525	FLBA6J0536K03	A	85.0	200.0	13.8	15.2	86.0	4560	8	375*285*365
3 x 57.7	525	FLBA6J0576K03	A	85.0	200.0	15.0	16.5	86.0	4950	8	375*285*365
3 x 77.0	525	FLBB6J0776K03	B	85.0	265.0	20.0	22.0	86.0	6600	8	375*285*365
3 x 77.0	525	FLBD6J0776K03	D	116.0	160.0	20.0	22.0	86.0	6600	5	375*285*235
3 x 96.2	525	FLBB6J0966K03	B	85.0	265.0	25.0	27.5	86.0	8250	8	375*285*365
3 x 96.2	525	FLBE6J0966K03	E	116.0	200.0	25.0	27.5	86.0	8250	5	375*285*365
3 x 115.4	525	FLBF6J1156K03	F	116.0	230.0	30.0	33.0	86.0	9900	5	375*285*365
3 x 115.4	525	FLBH6J1156K03	H	136.0	200.0	30.0	33.0	86.0	9900	2	375*285*365
3 x 138.2	525	FLBG6J1386K03	G	116.0	265.0	35.9	39.5	86.0	11850	5	375*285*365
3 x 138.2	525	FLBJ6J1386K03	J	136.0	230.0	35.9	39.5	86.0	11850	2	375*285*365
3 x 142.8	525	FLBG6J1426K03	G	116.0	265.0	37.1	40.8	86.0	12240	5	375*285*365
3 x 142.8	525	FLBJ6J1426K03	J	136.0	230.0	37.1	40.8	86.0	12240	2	375*285*365
V_{rms} = 660V Voltage Code: N											
3 x 20.3	660	FLBA6N0206K03	A	85.0	200.0	8.33	7.3	108.0	2190	8	375*285*365
3 x 24.4	660	FLBa6N0246K03	A	85.0	200.0	10.0	8.7	108.0	2610	8	375*285*365
3 x 30.4	660	FLBB6N0306K03	B	85.0	265.0	12.5	10.9	108.0	3270	8	375*285*365
3 x 36.5	660	FLBB6N0366K03	B	85.0	265.0	15.0	13.1	108.0	3930	8	375*285*365
3 x 40.7	660	FLBB6N0406K03	B	85.0	265.0	16.7	14.6	108.0	4380	8	375*285*365
3 x 48.7	660	FLBC6N0486K03	C	85.0	350.0	20.0	17.5	108.0	5250	8	375*285*435
3 x 55.8	660	FLBC6N0556K03	C	85.0	350.0	22.9	20.0	108.0	6000	8	375*285*435
V_{rms} = 690V Voltage Code: O											
3 x 27.9	690	FLBB6O0276K03	B	85.0	265.0	12.5	10.5	112.0	3150	8	375*285*365
3 x 33.4	690	FLBB6O0336K03	B	85.0	265.0	15.0	12.5	112.0	3750	8	375*285*365
3 x 44.6	690	FLBC6O0446K03	C	85.0	350.0	20.0	16.7	112.0	5010	8	375*285*435
3 x 55.7	690	FLBC6O0556K03	C	85.0	350.0	25.0	20.9	112.0	6270	8	375*285*435

* Insert K for 10% capacitance tolerance (standard); J (+5%) and M (+20%) tolerances available on request.

Values outside this standard range may be available – please contact KYOCERA AVX for any special requirements.

KYOCERA AVX reserves the right to supply capacitors to a tighter capacitance tolerance or higher voltage rating, in the same case size.