

# Product data sheet

Specifications



## Fixing unit for modular tower lights, Harmony XVU, black, 60mm, 3 pins direct mounting

XVUZ01

### Main

Range of product	Harmony XVU
Product or component type	Modular tower light
Accessory / separate part type	Mounting plate
Accessory / separate part category	Mounting and fixing accessory
Component name	XVU
Mounting diameter	60 mm

### Complementary

Number of pins	3
Mounting support	Direct mounting
Product compatibility	Top: AC body Top: DC body Top: swivel mounting support
Material	PBT (polybutylene terephthalate) V-0 conforming to UL 94 ABS (acrylonitrile butadiene-styrene) PC (polycarbonate)
Housing colour	Black
Connections - terminals	Push-in
[Us] rated supply voltage	24 V AC/DC 110...240 V AC
Length	17 mm
Net weight	0.063 kg

### Environment

Ambient air temperature for storage	-40...70 °C
Ambient air temperature for operation	-25...50 °C
IP degree of protection	IP65
Product certifications	CSA UL CE

Disclaimer: This documentation is not intended as a substitute for and is not to be used for determining suitability or reliability of these products for specific user applications

## Packing Units

Unit Type of Package 1	PCE
Number of Units in Package 1	1
Package 1 Height	9 cm
Package 1 Width	13.3 cm
Package 1 Length	9.1 cm
Package 1 Weight	150 g
Unit Type of Package 2	S03
Number of Units in Package 2	24
Package 2 Height	30 cm
Package 2 Width	30 cm
Package 2 Length	40 cm
Package 2 Weight	4.44 kg
Unit Type of Package 3	PAL
Number of Units in Package 3	192
Package 3 Height	60 cm
Package 3 Width	80 cm
Package 3 Length	70 cm
Package 3 Weight	36.8 kg

## Offer Sustainability

Sustainable offer status	Green Premium product
REACH Regulation	<a href="#">REACH Declaration</a>
EU RoHS Directive	Pro-active compliance (Product out of EU RoHS legal scope) <a href="#">EU RoHS Declaration</a>
Mercury free	Yes
China RoHS Regulation	<a href="#">China RoHS declaration</a>
RoHS exemption information	<a href="#">Yes</a>
Environmental Disclosure	<a href="#">Product Environmental Profile</a>
Circularity Profile	<a href="#">End of Life Information</a>
California proposition 65	WARNING: This product can expose you to chemicals including: Lead and lead compounds, which is known to the State of California to cause cancer and birth defects or other reproductive harm. For more information go to <a href="http://www.P65Warnings.ca.gov">www.P65Warnings.ca.gov</a>

**Fixing Unit**

---

**Dimensions**

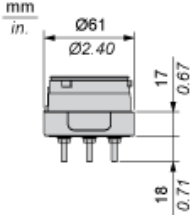

**Modular Tower Lights Mounting**

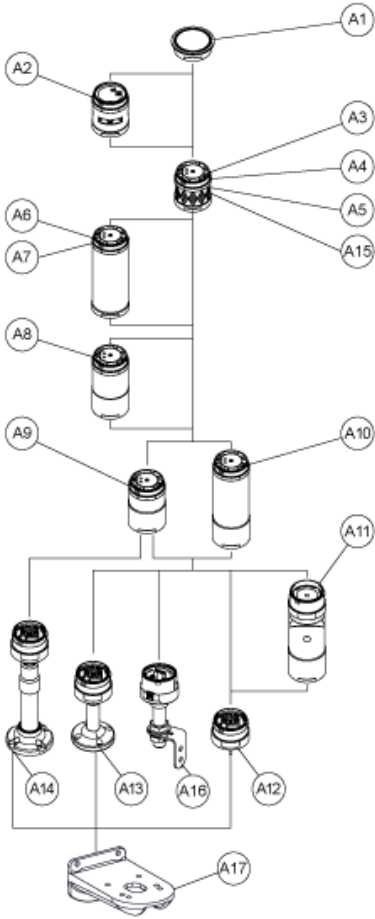

Drawing	Part number	Part name
A1	-	Top cover
	-	Top cover (Silver)
A2	XVUC9S	Buzzer unit
	XVUC9SQ	Buzzer unit (Silver)
A3	XVUC23	Green LED unit
	XVUC24	Red LED unit
	XVUC25	Orange LED unit
	XVUC26	Blue LED unit
	XVUC27	White LED unit
	XVUC28	Yellow LED unit
A4	XVUC29	Multi-LED unit
A5	XVUC29P	Multi-LED unit, Pulse signal
A6	XVUC9V	Sound unit
A7	XVUC9VP	Sound unit, Pulse signal
A8	XVUC020	Extender
	XVUC020Q	Extender (Silver)
A9	XVUC21B	DC body
	XVUC21BQ	DC body (Silver)
A10	XVUC21M	AC body NPN
	XVUC21MP	AC body PNP
	XVUC21MQP	AC body PNP (Silver)
A11	XVUZ06	Flexible option
A12	XVUZ01	Fixing Unit - Direct mounting (3 pins)
	XVUZ01Q	Fixing Unit - Direct mounting (Silver,3 pins)
	XVUZ03	Fixing Unit - Direct mounting (2 pins)
	XVUZ04	Fixing Unit - Direct mounting (4 pins)

Drawing	Part number	Part name
<b>A13</b>	XVUZ02	Fixing Unit - Plate with Pole (100 mm)
	XVUZ02Q	Fixing Unit - Plate with Pole (100 mm, Silver)
	XVUZ400	Fixing Unit - Plate with Pole (400 mm)
	XVUZ800	Fixing Unit - Plate with Pole (800 mm)
<b>A14</b>	XVUZ05	Fixing Unit - Plate with adjustment pole (100-385 mm)
<b>A15</b>	XVUC43	Green LED unit, Flash
	XVUC44	Red LED unit, Flash
	XVUC45	Orange LED unit, Flash
	XVUC46	Blue LED unit, Flash
	XVUC47	White LED unit, Flash
	XVUC48	Yellow LED unit, Flash
<b>A16</b>	XVUZ100T	Fixing Unit - Metal bracket with pole (100 mm)
	XVUZ250T	Fixing Unit - Metal bracket with pole(250 mm)
	XVUZ400T	Fixing Unit - Metal bracket with pole (400 mm)
<b>A17</b>	XVUZ12	Fixing plate for use on vertical support - black

**Modular Tower Lights Mounting**

---

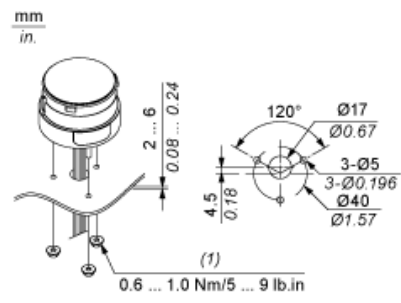

(1) M4 Nut x 3 (attached)

**Flexible Option Mounting**

---

**Recommended Mounting**

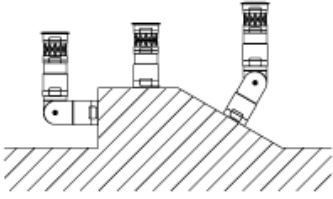

**No Recommended Mounting**

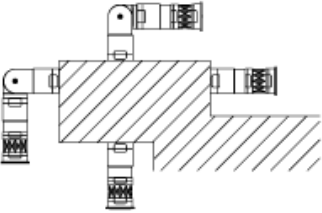

**Illuminated Units, Multi-LED and Audible Units Wiring**

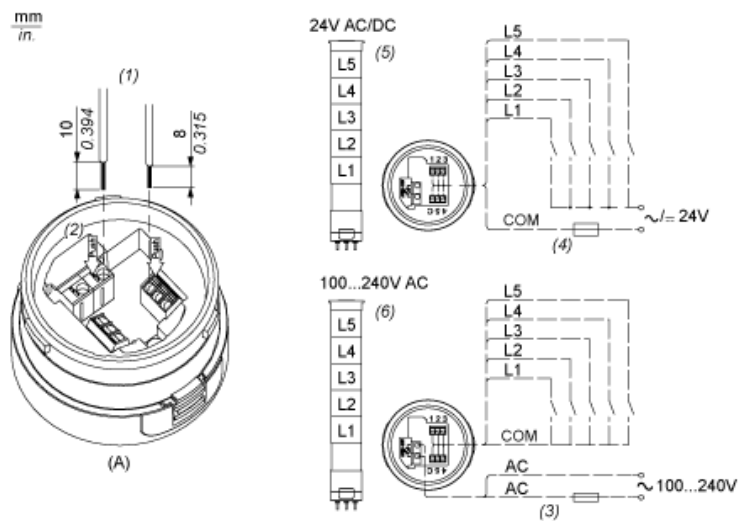

- (A) Fixing Unit
  - (1) Dimensions of Wiring size
  - (2) Push-in Wire Connectors
  - (3) Fuse : 2A ,250V
  - (4) Fuse : 0.5A ,125V
  - (5) Modular Tower Lights 24V AC/DC
  - (6) Modular Tower Lights 100...240V AC
- L1 to L5 Illuminated LED Units

**Recommended replacement(s)**